

QZT-400

Spine Cutter 切中条机

QZT-400 Spine Cutter is our new developed equipment to cut the spine strip of folder, book covers and package box etc. It is the auxiliary equipment for the case making machine.

QZT-400型切中条机是我公司新开发出的一种与纸板分切机配套的设备，其主要作用就是裁切文件夹、书刊封面和书壳式包装盒的中缝纸板。

MAIN SPECIFICATION 主要技术参数

Model	型号	QZT-400
Minimum spine width	最小分切宽度	5mm
Maximum spine width	最大分切宽度	55mm
Maximum board thickness	最大纸板厚度	3mm
Maximum spine length	最大分切长度	400mm
Power	功率	1.1kw
Dimension (LxWxH)	外形尺寸	1300×1000×1200mm
Weight	整机重量	600kg

MAIN FEATURES 性能特点

The machine uses the special eccentric cam drive structure to perform the automatic board feeding and length adjusting easily with high accuracy and central lubricant as well as convenient maintenance.

该机采用独特的偏心轮传动结构，自动进给纸板，长度调节方便，不但裁切速度快，而且精度高，采用集中加油润滑，维护方便。

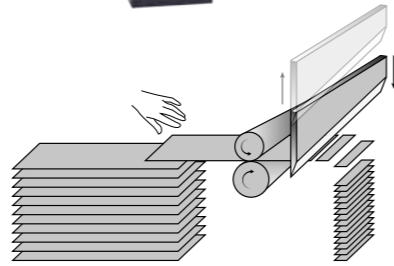

The working principle of the cardboard cutting
纸板裁切成型工作原理

KC-1000

Grooving Machine 开槽机

This machine is specially designed for notching v type groove of industrial paperboard, grey board, MDF board and other kinds of cardboard. It adopts new structure of board conveying, wrapping the cardboard on the entire surface of the roller. It can guarantee the groove more accurate (no deviation) and straight. This machine has the features of high accuracy, fast speed and durable cutting blade.

本机是专业针对各种工业纸板、灰纸板、木板等各种板材开V槽。采用新型的输送纸板机构，把要开槽的纸板整个平面包在滚筒上，保证开槽的定位准确，没有偏差，开槽的直线性高。具有高精度、高速度、刀具耐用等特点。

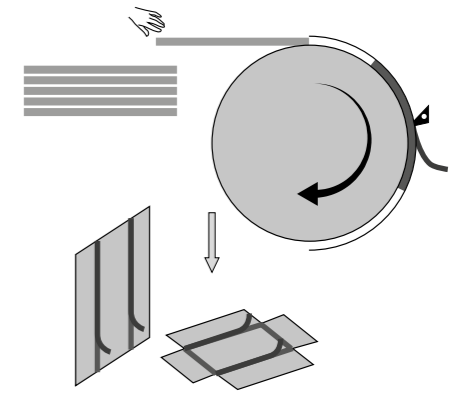

MAIN SPECIFICATION 主要技术参数

Model	型号	KQ-1000
Width of cardboard	加工纸板宽度	100-950mm
Length of cardboard	加工纸板长度	100-950mm
Distance of each groove	开槽间距	0-830mm
Thickness of cardboard	纸板厚宽	0.5-4mm
Grooving degree	开槽角度	60-150°大小可调 adjustable
The amount of groove	同时开槽条数	9 pieces one time
Production speed	开槽速度	10-40m/min
Power	功率	2.2kw/380V
Dimensions (LxWxH)	外形尺寸	1500×1400×1600mm
Weight	整机重量	1200kg



QJ-80

Angle Cutter 电动切角机



The structure of this machine is fine and compact, and easy operation with stable performance. It is suitable for cutting various paper angle. 此机结构精细紧凑，操作方便，性能稳定，可适用于裁切各种纸板及纸张的斜角。

MAIN SPECIFICATION 主要技术参数

Model	型号	QJ-80
Paper height	纸张高度	≤80mm
Cutting width	切角宽度	≤40mm
Cutting speed	切角速度	85times/min
Motor power	电机功率	0.75kw/380v
Machine dimension	机械尺寸	1350x500x1200
Machine weight	机械重量	270kg

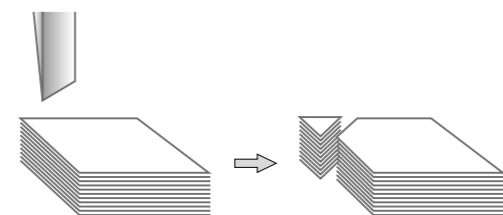

QJ-30

Manual Angle Cutter 手动切角机

MAIN SPECIFICATION 主要技术参数

	型号	QJ-30
Cutting Height	切角高度	≤30mm
Cutting width	切角宽度	≤40mm
Weight	机器重量	75Kg
Size	外形尺寸	340×380×650mm